

7804

ELECTRIC HEAT PUMP MODEL

DRYING CABINET



Drying Cabinets have no mechanical action and are used to efficiently dry bulky items such as workwear/overalls/gloves and boots.

PRIORITY ON PEOPLE

Ergonomic design, with user friendly positioning of door handle, control panel and suitable for disabled users.

- Easy operation with 2 automatic drying programs, which will stop once the load is dry
- 18-20 extendable hangers for easy loading/unloading, reversible
- Flexible installation with adjustable feet
- Insulated doors for quiet operation and robust design

LONG-TERM SAVINGS

By using a Drying Cabinet with a Heat Pump, not only can you avoid exhaust connection you can reach energy saving of 40% compared with an electric vented version. There are two options of heat pump versions.

PRODUCTIVITY

Time saving when used instead of flat or hang drying. The door can be opened a short moment without stopping the drying process.

ACCESSORIES

Main specifications		7804
Rated capacity	kg	8
Evaporation*	g/min	50
Drying time cotton*	min	60
Rated input	kW	2.3
Energy/load of linen	kWh/kg	0.35
Energy/water evaporated	kWh/l	0.70

* Applies to 8 kg dry weight cotton with 50% residual moisture.
We reserve the right to alter specifications without notice.



Shoe rack: Make it easier to dry shoes and boots.



Glove hanger: More efficient drying of gloves, hats etc.



Hanger: Makes hanging of garments easier.

WASHGUARD

WashGuard offers the ultimate waterproof, chemical resistant solution to keep your hygiene operators protected.

www.foodclean.com/protect

BIBS & BRACES

COVERALLS

JACKETS

TROUSERS

SMOCKS

APRONS

WELLINGTONS

GLOVES

GOGGLES





Electrical connection		7804
Voltage	400V 3N AC 50 Hz	
Traditional thread locker	kW(A)	2.3(10)
Automatic circuit breaker	kW(A)	2.3(10)
Sound level		
Pressure level**	dB(A)	<70
Weight		
	net kg	189

Dimensions in mm			
A Width	1195	E	1080
B Depth	645	F	90
C Height	2060	G	2075
D	425	H	435
1. Operating panel	2. Condensation nipple \varnothing 18 mm and 3 m hose included		



Colour of front and side panels is silver grey and handle is dark blue.

* Sound power levels measured according to ISO 60704

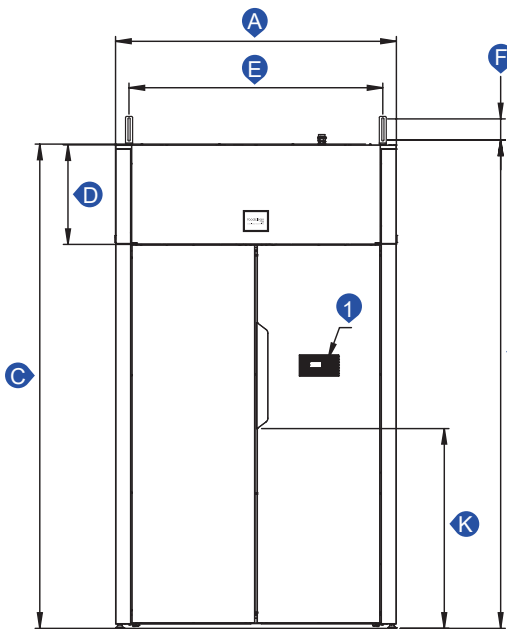

Front

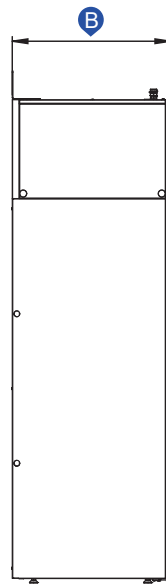

Left side

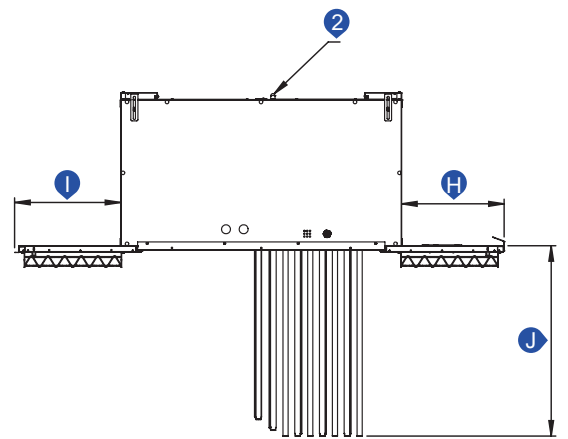

Top view

Saxilby Enterprise Park
Skellingthorpe Road
Lincoln
LN1 2LR
United Kingdom

UK
T: +44 (0) 1522 703703
E: info@foodclean.com
W: www.foodclean.com



France
T: +33 (0)1 70 75 26 82
E: commercial@foodclean.com
W: www.foodclean.fr



foodclean
BY **QJS**

SUSTAINABLE FOOD HYGIENE